

## POLISHED GOLD FINISH DECK MOUNT COMMERCIAL SENSOR SOAP DISPENSER WITH HORIZONTAL LINES DESIGN OVER IT SPECIFICATIONS

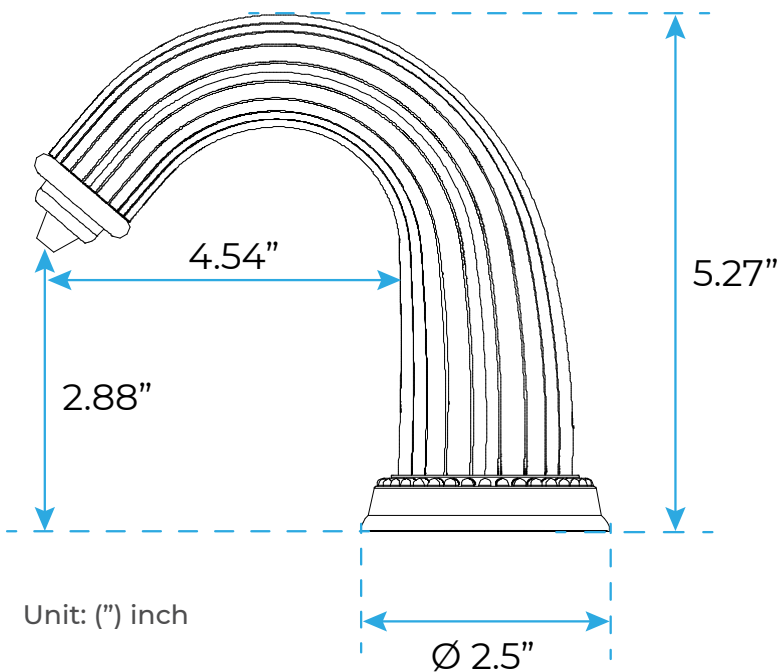

Specification	
Product Type:	Commercial
Main Construction Material:	Brass
Mount Type:	Deck
Handle Type:	Infra-Red
Power Rating:	3 Amp Fuse, AC: 230V DC: 1.5V
Batteries Required:	4 AA Batteries (not supplied)
Number of Tap Holes:	1
Valve/Cartridge Type:	Solenoid Valve
Soap Pump	6 Volt Noise-Free PERISTALTIC Pump System
Sensing Range:	4.75 inches
Soap Bottle Capacity:	1000 ml
Soap Type:	Standard Liquid Soap

### Size



All dimensions and specifications are nominal and may vary. Use actual products for accuracy in critical situations.